

# Toin Science Club CanSat Team

## Pre-Launch Report

Sayama Kosuke: Programming

Takimoto Eichi : Programming

Nishioka Ukyo: Making parachute

Shibata Rei: Production of CanSat

Iwata Takumi: Production of CanSat



# Contents

<b>1.Mission</b> .....	3
1-1 Details	
1-2 Meaning	
1-3 Method	
1-4 Measured data .....	4
<b>2.Hardware</b>	
2-1 Structure and role of CanSat	
2-2 Protection product .....	5
<b>3.Budget</b> .....	7
<b>3.Program</b> .....	9
3-1 Wireless communication	
3-2 Data measuring CanSat's Program	
3-3 Software	
3-4 Rendering Program	
<b>4.References</b> .....	11

# 1. Mission

Our mission is Rendering CanSat's moving path and reproducing CanSat's attitude.

## 1-1 Details

We try the following things.

1: Do real time rendering CanSat's moving path by using height data and GNSS data. —(Method1)

(Height data is calculated from temperature and air pressure)

2: Do real time rendering of the attitude of CanSat by utilizing quaternion data received from 9-axis sensor which is arranged at the center of gravity of CanSat.

3: Estimate position by using acceleration data and attitude data. —(Method2)

In the competition, the practicability of method2 is evaluated by comparing the data obtained from method1 and method2.

## 1-2 Meaning

It is more effective to determine the position and attitude of CanSat for utilizing the data gotten from CanSat.

And, it is impossible to determine the current location by method1 in space where we cannot use GNSS.

We expect it to show that method2 is a useful way to estimate location in space.

## 1-3 Method

1: Calculate Altitude by the formula below.

$$h = \frac{\left( \left( \frac{P_0}{P} \right)^{\frac{1}{5.257}} - 1 \right) \times (T + 273.15)}{0.0065}$$

h: Height(m)

P<sub>0</sub>=1013.25(hPa)

P: Pressure(hPa)

T: Temperature(Celsius degree)

2: 9-axis sensor(BNO055) is arranged at the center of gravity of CanSat, and we render CanSat's attitude by using quaternion data from BNO055.

3: 2 acceleration sensors are arranged at diagonal on the same plane, and 1 acceleration sensor is arranged at the center.

We remove centrifugal force from the two axis by taking averages of the former 2 data, and we removed it from another axis by comparing averaged data with the center acceleration sensor's data.

We got Accel information by using this method.

We try to remove gravity component by using this information and CanSat's attitude(method2).

Finally we calculate moving distance with integration.

## 1-4 Measured data

We will measure the following data.

Temperature data

Air pressure data

Illuminance data

GNSS data

Acceleration data

Angular velocity

Magnetic field strength

We will use the measured data for the following things.

Estimating the launch timing of the rocket and CanSat.

Rendering the CanSat's moving path and attitude.

Estimating the CanSat's position.

## 2. Hardware

### 2-1 Structure and role of CanSat

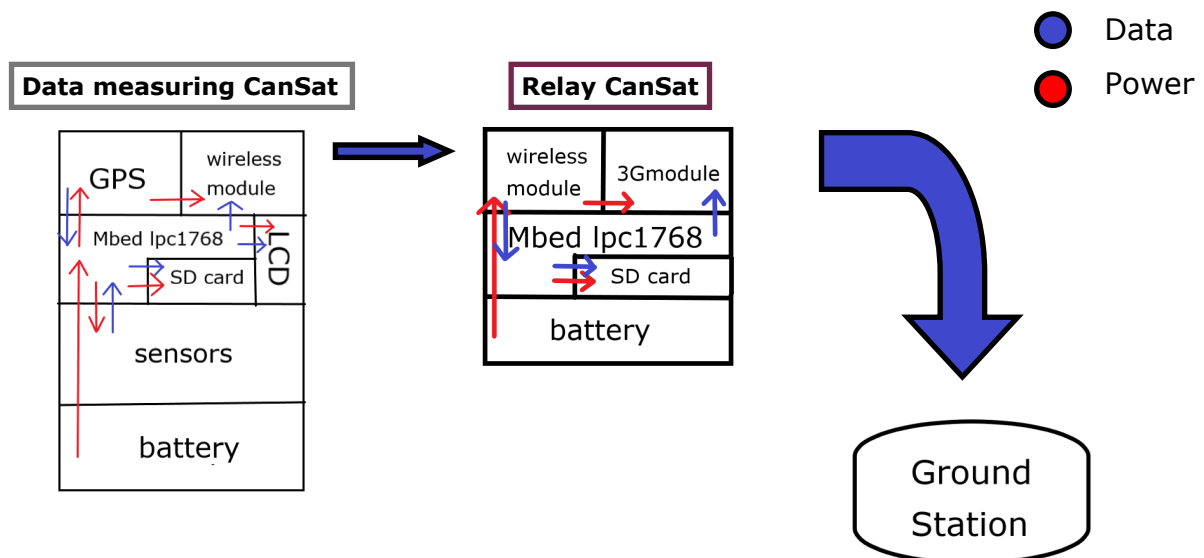

First, launch the data measuring and relay CanSats. \*1



Next, the data measuring CanSat mounted with sensors collect the data and transmit them to the relay CanSat.



Finally, the relay CanSat transmit the data to the Ground Station. \*2

(\*1 : We separate the functions into two CanSats because of lack of power current and enough space to mount with the modules.)

(\*2 : The communication used only the wireless module has a very high probability of not reaching the Ground Station because its transmission distance is short.

For this reason, we use the wireless and 3G modules.)

Data measuring CanSat

Relay CanSat

Use applications	Model number	Use applications	Model number
Air pressure sensor	LPS22HB	Microcomputer board	LPC1768
Illuminance sensor	TSL2561	Wireless communication module	XBee3
Acceleration sensor	MPU9250	3G wireless communication module	XBC-M5-UT-001
9DoF sensor	DSR1603(BNO055)		
GPS	AE-GYSFDMAXB		
Wireless communication module	XBee3		

### Sensor cover

Our team needed to obtain more accurate numbers in order to use air pressure sensor data for CanSat altitude estimation. We proved that the sensor value changes when fixed air pressure sensor is exposed to the wind of the blower. We thought that this change may disturb the value of the air pressure sensor even in the air, and attached the sensor cover to prevent it. This cover is made of melamine sponge used for "cleaning sponge."

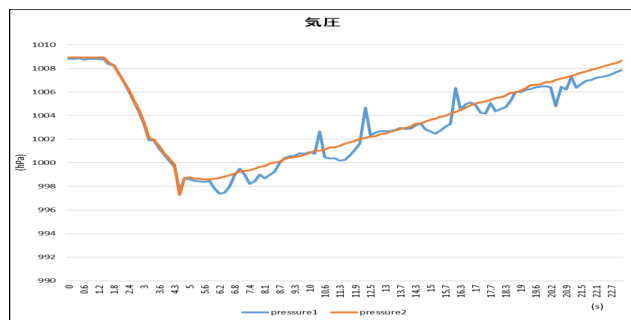
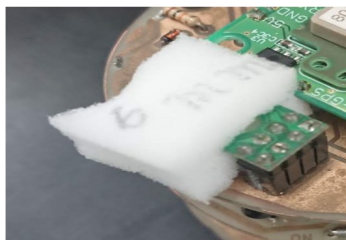

In preliminary experiments, we made a CanSat equipped with two air pressure sensors. One was covered and the other was untouched. The orange graph (covered sensor) reduces the fluctuation of the value that is presumed to have been produced by the wind on the sensor.

## 2-2 Protection product

### Parachute

We designed and manufactured the parachute as follows according to the guidelines from ESA.

**[SHAPE]**

Hexagon with seven Spill hole

**[MATERIAL]**

Canopy ... Satin fabric (polyester 100%)

Parachute line ... Kite string



(picture 1) parachute

**[SIZE]**

We calculated the size of the parachute from the formula below, and set the diameter of it to 40cm and 50cm.

$$S = \frac{2mg}{PV^2Cd}$$

$$D = \frac{\sqrt{4S}}{\sqrt{\pi}}$$

S: summation (m<sup>2</sup>) P: 1.17 (kg/m<sup>3</sup>) D: diameter (m)  
 m: 0.3 kg V: velocity (m/s) n: 3.14159  
 g: 9.81 m/s<sup>2</sup> Cd: 0.77

**[ENDURANCE TEST]**

- 1: Put a 500N weight on the canopy.
- 2: Hold the parachute line and pull it up.

**[TERMINAL VELOCITY]**

We dropped the parachute from a point of 12m above the ground, and calculated the terminal velocity.

diameter (cm)	Terminal velocity (m/s)
40	7.83
50	7.19

**[BUDGET]**

	Canopy	Parachute line	Total
Euro (€)	0.77	0.24	1.01
yen (¥)	94.3	29.16	123.46

## Shock absorption mechanism

We made a honeycomb mechanism using paper as a shock absorbing mechanism. Made of paper it is easy and inexpensive to obtain materials. The hardness of the honeycomb mechanism can be easily manipulated by adjusting the length of the short side of the hexagon forming the honeycomb mechanism. Since electricity is not used for operation, even if the CanSat does not move, the honeycomb mechanism is broken to weaken the impact that the CanSat receives.



## Protective cover

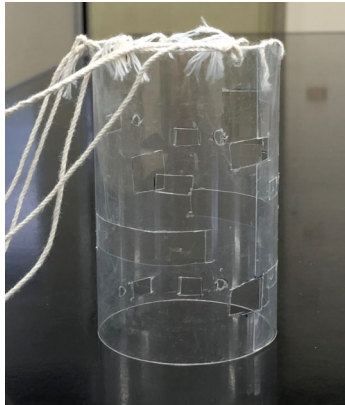

We used PET (polyethylene terephthalate) to make the CanSat protective cover. PET is cheap and easy to obtain, light and durable. Unlike metal covers, it has the advantage of not blocking radio waves. It can be disposable as it can be easily produced.

# 3. Budget

## Parachute

	Canopy	Parachute line	Total
Euro (€)	0.77	0.24	1.01
yen (¥)	94.3	29.16	123.46

Shock absorption mechanism      0yen

Protective cover                      0yen

CanSat

Mfr.#:	Price(JPY)	Qty.	Ext.(JPY)
XBC-M5-UT-001	10,368.5	1	10,368.5
PC29.07.0100A	1,321.1	1	1,321.1
MPM80	250	1	250
ADT7410	500	1	500
LPS22HB	900	1	900
TSL2561	600	1	600
AE-GYSFDMAXB	2,100	2	4,200
MPU9250	2,000	3	6,000
DSR1603	6,480	1	6,480
NZ-G34KR	1,580	2	3,160
AQM0802A-RN-GBW	320	1	320
CR-2032/2P	648	1	648
DM3CS-SF	177	2	354
LPC1768	5,940	2	11,880
PB04-SE12HPR	100	2	200
BH-431-1A150	60	1	60
BH-9V-1A	60	1	60
HT7750A	500	1	500
BK-4MLE/4B	1,472	0.75	1,104
6LR61 9V	259	1	259
Resistance, Spacer, Code, etc.	2,000	1	2,000
TOTAL			51,164.6

Total 51,288.06 yen

**418.00€**

€1=¥122.70(2019/6/9 15:10)



# 3. Program

## 3-1 Wireless communication

Wireless communication: Replace the data we want to send with one digit hexadecimal number, and wirelessly transmit the two characters as one-character ASCII code.

Also, as a data reception judgment, a 3-digit hexadecimal checksum is implemented.

Furthermore, by dividing the transmission according to the data type, it is possible to acquire data even if all the data are not complete.

Original String	"0"	"1"	"2"	"3"	"4"	"5"	"6"	"7"	"8"	"9"	","	","	"inf"	"nan"	","	Others
Encoded Data	0	1	2	3	4	5	6	7	8	9	A	B	C	D	E	F

	Front	Data type	Count		Time		Temperature		Pressure1		Pressure2	Checksum	Back
Data->			9581	,	276.911102	,	26.515625	,	994.179199	,	1000.285889		
Encoded Data->	F	0	9581	E	276A911102	E	26A515625	E	994A179199	E	1000A285889	A0E	F0D0A

Sum:F0+95+81+E2+76+A9+11+10+2E+26+A5+15+62+5E+99+4A+17+91+99+E1+00+0A+28+58+89=A0E (If sum is 12A5, the checksum value will be 2A5)

## 3-2 Data measuring CanSat's Program

LCD

The LCD displays text that indicates the current CanSat mode, and counts when measuring data.

Maintenance mode

When using the maintenance mode, by connecting the CanSat with a PC with a USB cable, the values of each sensor can be checked in real time by serial communication.

As a result, it can be easily confirmed whether the sensor is operating normally or wireless data is normally transmitted.

This is expected to lead to early detection of abnormalities.

## 3-3 Software

Data measuring CanSat: mbed OS 2

Relay CanSat: mbed OS 5

Ground Station & Rendering: Processing

## 3-4 Rendering Program

Treat the earth as a true sphere with a circumference of 40,000 km, taking the latitude at the start of data acquisition as  $\theta$ , multiply  $\cos \theta$  by 40,000 km to calculate the length of the latitude line, and construct a pseudo plane representing a part of the earth and make it correspond to the latitude and longitude.

## Real time rendering mode

Improve the CanSat recovery probability by displaying the current location and the horizontal distance and direction to the latest location of CanSat.

## CSV playback mode

From the collected data of CanSat, the position information can be reproduced according to the actual time.

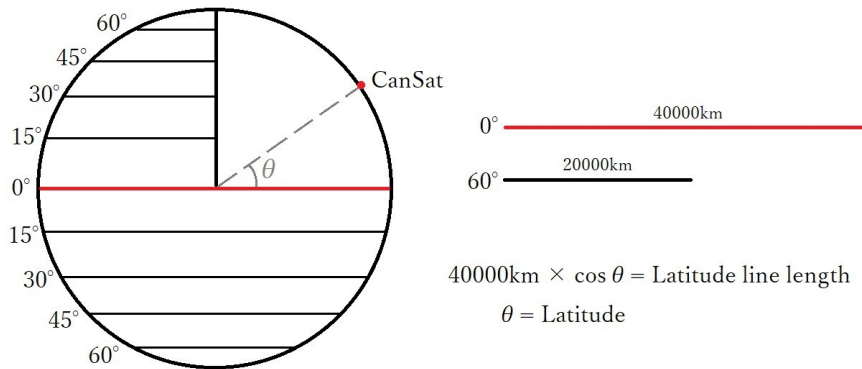

Render the CanSat attitude using Quaternion data calculated by BNO055.

Although the amount of data decreases when using the Euler angle represented by Yaw angle, Pitch angle, and Roll angle, problems specific to BNO055 occur.

(Yaw angle becomes unstable when Pitch angle or Roll angle becomes larger than  $\pm 45^\circ$ )

There is also the problem that gimbal lock occurs.

So we use Quaternion data to avoid these problems.

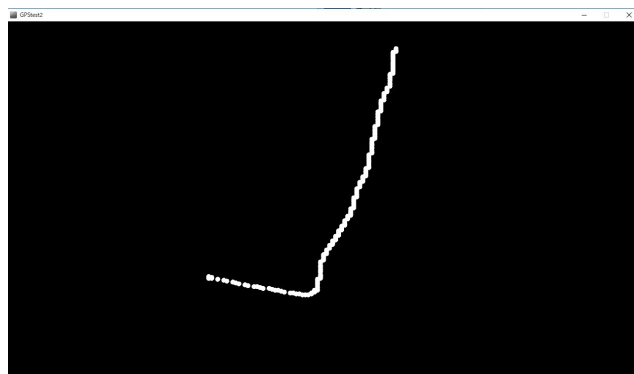

After recovering the CanSat, using acceleration data and attitude data, we try to estimate position by the method described in the mission section, and compare it with the moving path by GPS and altitude.

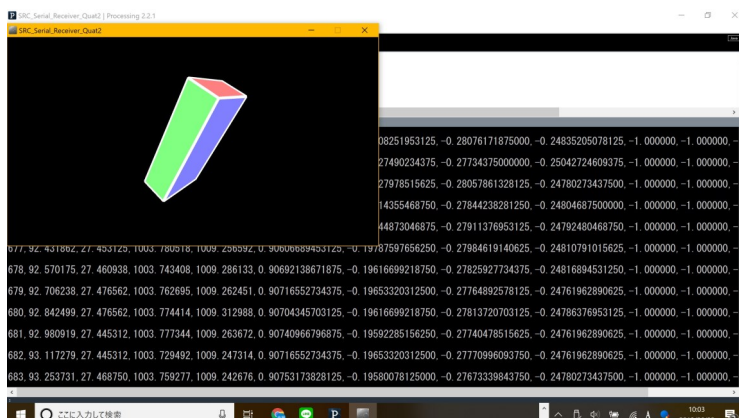

# 4.References

keisan 生活や実務で役立つ計算サイト (2019/6/9)

<https://keisan.casio.jp/exec/system/1257609530>

Digi XBee Cellular Embedded Module (2019/6/9)

[https://www.digi.com/resources/documentation/digidocs/90001525/default.htm#reference/r\\_purchase\\_sim.htm%3FTocPath%3DDigi%2520XBee%2520Cellular%2520Embedded%2520Modem%2520User%2520Guide%7C\\_\\_\\_\\_\\_2](https://www.digi.com/resources/documentation/digidocs/90001525/default.htm#reference/r_purchase_sim.htm%3FTocPath%3DDigi%2520XBee%2520Cellular%2520Embedded%2520Modem%2520User%2520Guide%7C_____2)

Recommendations For Teams 2019.pdf (ESA)